

weighing
bagging
checking
registration
communication



Our product lines for a custom made bagging solution!



Professional Bagging Systems

Bagging Systems

Servo Berkel Prior specializes in engineering and manufacturing of different types of weighing machines. They find frequent and world wide application in many branches of industry.

For over 70 years Servo Berkel Prior produces standard and dedicated systems for the bagging of all kinds of products in bags. Each system meets the specific requirements of the end user.

Semi- automatic OIML approvable Single- and Twin bagging scales and lines for the bagging and sewing of the bags;

- For the weighing and bagging of all kind of products like sugar, cattle feed pellets and flour, cocoa beans, granulates, fishmeal, several powder products, grains, seeds etc.
- Weighing capacities available for the bagging of 20, 25, 50 and up to 100 kg bags
- Capacities possible to 400 ~ 500 bags per hour on a single weigher and up to 1200 bags per hour on a Twin- bagging scale
- Several types of in-feed dosing systems for filling of the weighing hopper, by a butterfly valve, segment valve, sleeve, motorized screw, vibrating trough etc.
- Volume of the weighing hopper depends on the weighing capacity of the bagging scale and provided with round corners and a discharge valve
- Bagging scale with a closed (and) removable housing for internal cleaning and servicing
- Weighing system with 1 (one) stainless loadcell for a high accuracy
- Receiving bin with bagging mouth with clamp and hand safety protection
- Custom made suspension frame for hanging up the weigher or for support on the floor (to discuss)
- Complete with a control box included a Control/Process Weighing Indicator with set-point module for rough and fine filling, checking and monitoring, printing etc. Connection to printer, PC's and PLC's by serial outputs, Ethernet and Profibus
- Standard in painted steel, optional stainless steel class 304 or 316L
- ATEX versions for Zone 22 are also available, other ATEX zones on request possible
- For complete bagging lines are available sewing machines with bag conveyors, checkweighers, metal detectors, palletizing machines and robots

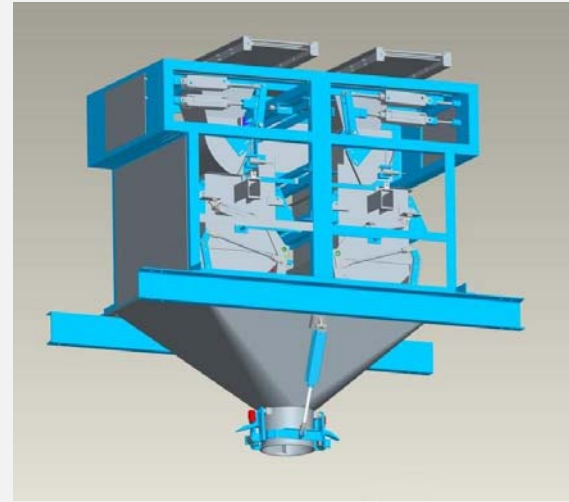
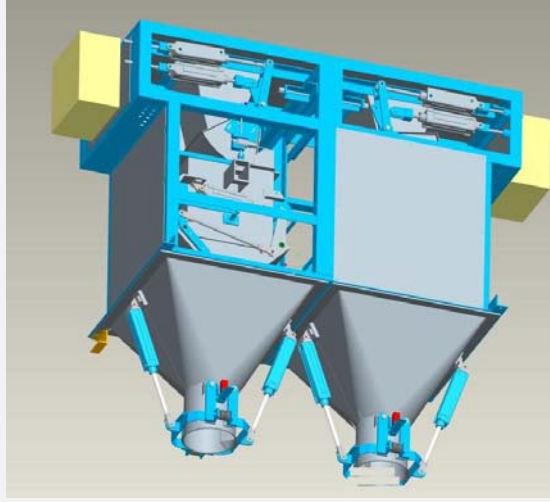
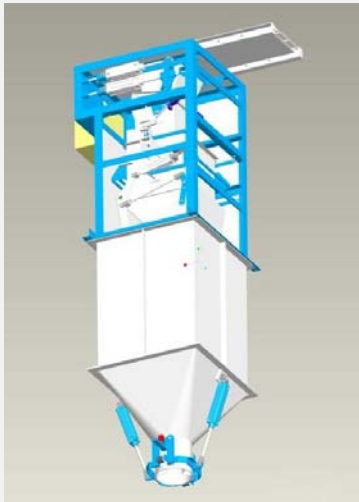

Professional Bagging Systems

Bagging Systems

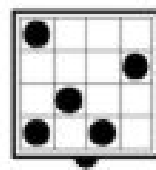

Quality guarantee

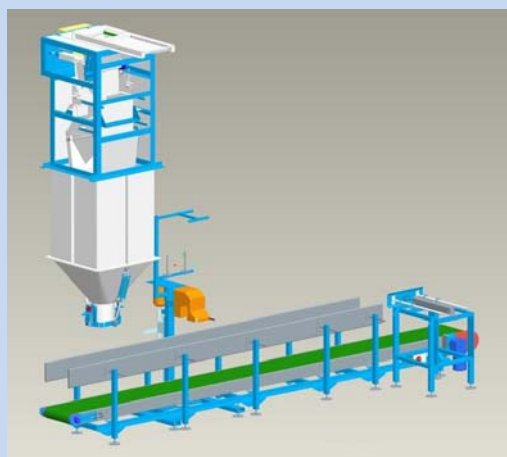

Professional Bagging Systems

Servo Berkel Prior B.V.

Jan Evertsenlaan 4 - NL-2224 SV Katwijk
P.O. Box 2032 - NL-2220 BA Katwijk

T. +31 (0) 71 403 01 01
F. +31 (0) 71 403 23 17
E. sales@servoberkelprior.eu
www.servoberkelprior.eu