

take in
loading
checking
communication
registration



Development

Knowledge



Professional Duplexweighers

Duplexweighers

Servo Berkel Prior specializes in engineering and manufacturing of different types of weighing machines. They find frequent and world wide application in many branches of industry.

For over 70 years Servo Berkel Prior produces standard and dedicated systems for Continuous and Bulkweighing of all kind of materials. Each system meets the specific requirements of the end user.

Fully automatic discontinuous throughput weighing systems for products/materials like sugar, cocoa beans, grain, flower, meals, salt, potatoes, fertilizers, chemicals, synthetic/fibre products, molasses, sugar juice etc.

Our systems are or can be provided or delivered with;

- Capacities from 5 up to 3000 ton per hour
- Included with a supply hopper with single- or double segment valves (depends on the required capacity/hour), volume of this hopper depends on the weighing capacity per batch and bulk density of the product
- Included with a weighing hopper with single- or double segment valves (depends on the required capacity/hour), volume of this hopper depends on the weighing capacity per batch and bulk density of the product
- Weighing hopper with internal dust circulation system (external dust collection/extraction not necessary)
- Weighing system with the unique Servo Balans hybrid weighing system with levers with stainless steel bands and a transmission of the weight to 1 (one) Servo Balans stainless steel loadcell. This system guarantees a highly accurate weighing performance and has proven to be the most insensitive system against any surrounding disturbances (e.g. vibrations and the like). If request is a fully electronic weighing with loadcells also possible
- A discharge funnel or hopper is not standard and can be delivered as an option
- Movable mobile solutions are available; ideal to use on various docks in a harbour
- ATEX version for Dust Zone 21 and 22 available
- Standard with weight racks for calibration; automatic test weighing device as an option
- Complete with control cabinet, Weighing Terminal and Process Controller/System Software
- Optional Profibus communication with PLC or DCS
- The Duplexweighers can be delivered in painted mild steel, partly or complete in stainless steel 304 and/or 316L (food specificat)
- Our Duplexweighers and Process Controllers are made in the EU; quality of workmanship will be first class standard!
- We manufacture and deliver conformation the European CE rules
- Accuracy in accordance with the European Statutory Guideline R107 for a discontinuous totalizing weighing system (accuracy totalizing 2 ‰ or better)
- A Custom Made weigher is for us not a special!



Professional Duplexweighers

Duplexweighers

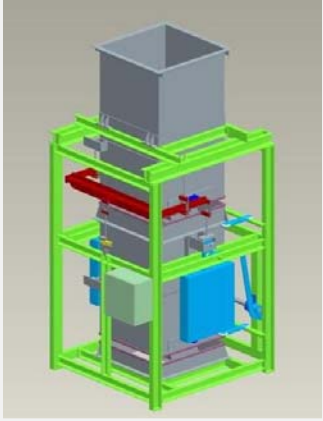

Solids Weigher
Capacity up to 50 ton/hour

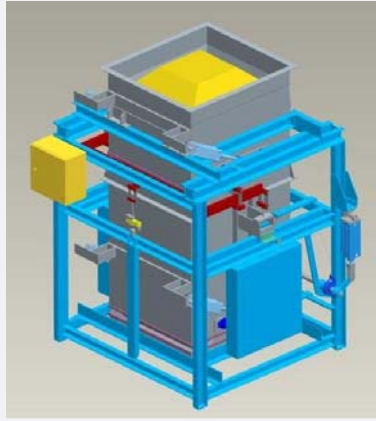

Solids Weigher
Capacity up to 100 ton/hour

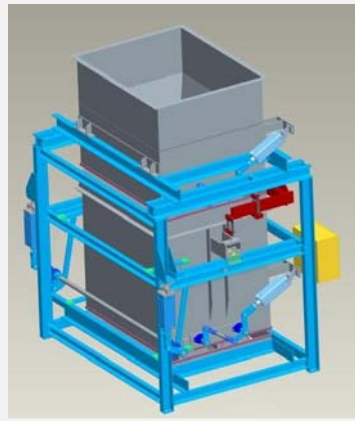

Solids Weigher
Capacity up to 150 ton/hour

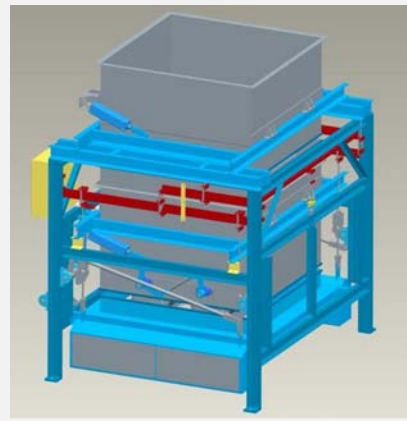

Solids Weigher
Capacity up to 200 ton/hour

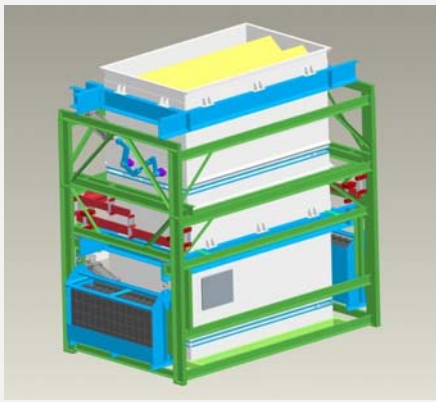

Solids Weigher
Capacity up to 300 ton/hour

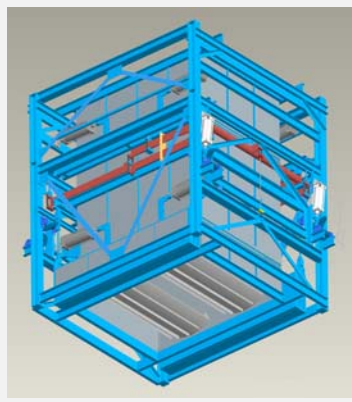

Solids Weigher
Capacity up to 1000 ton/hour

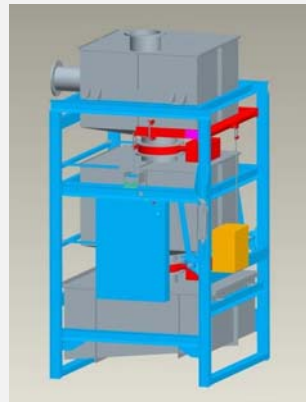

Molasses Weigher
Capacity from 5 ton/hour >>



Juice Weigher
Capacity from 50 ton/hour >>

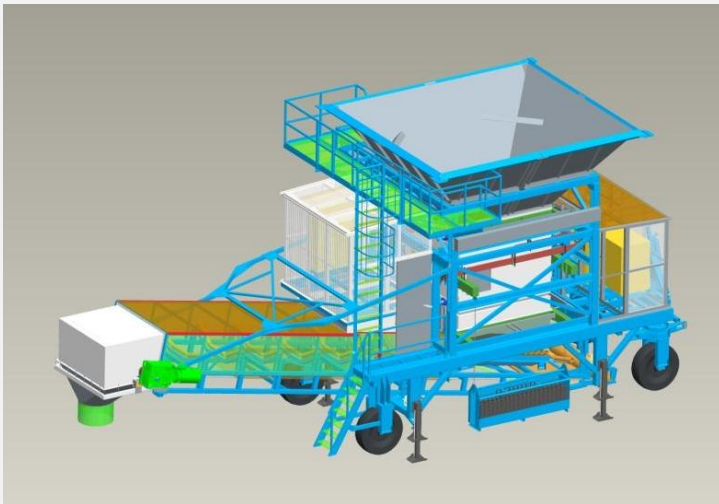

Movable Harbor Weighers
Capacity 600 ton/hour

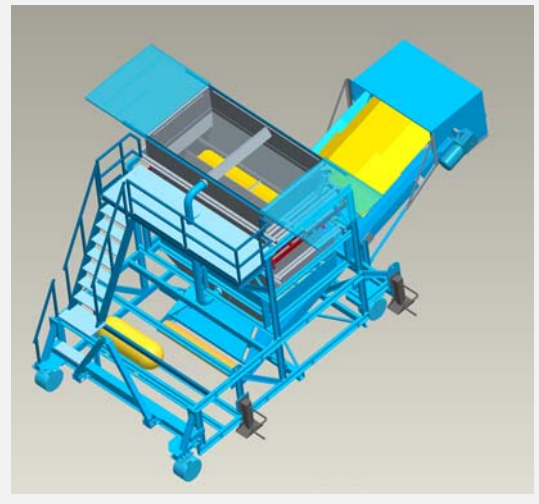

Movable Harbor Weighers
Capacity 500 ton/hour

Professional Duplexweighers

Duplexweighers

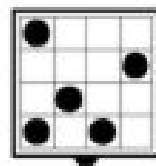

Quality guarantee

References



Professional Duplexweighers

Servo Berkel Prior B.V.

Jan Evertsenlaan 4 - NL-2224 SV Katwijk
P.O.Box 2032 - NL-2220 BA Katwijk

T. +31 (0) 71 403 01 01
F. +31 (0) 71 403 23 17
E. sales@servoberkelprior.eu
www.servoberkelprior.eu