

weighing
checking
registration
labeling
communication

Servo Berkel Prior
Unified Weighing Solutions



Our product lines for a custom made checkweighing solution!



Professional Checkweighers

Checkweighers

Servo Berkel Prior specializes in engineering and manufacturing of different types of weighing machines. They find frequent and world wide application in many branches of industry.

For over 70 years Servo Berkel Prior produces standard and dedicated systems for the weighing, checking and labeling of all kind of packaging's and products. Each system meets the specific requirements of the end user.

Fully- automatic OIML approvable Beltweighing systems for the weighing, checking and labeling carton packaging's, boxes, bags and products like cheeses

- Start/Stop weighing system for the weighing of the products passing at relatively low speed
- In-motion weighing system for the weighing of the products passing at higher speeds
- Weighing capacities from 3 till 100 kg
- Weight increments 3000d (OIML approved)
- Length of the conveyors depend on the required capacity per hour, general speed of the factories production line, product size etc.
- Separation conveyor separate the products before they arrive at the weigh conveyor
- Weigh conveyor with full load cell or hybrid weighing system
- Discharge conveyor with eject or reject facilities
- Products are controlled on correct weight and accepted/ incorrect weight and rejected /or classified and conveyed into different weight ranges
- Label- or inkjet printers enabling on-line labeling or direct printing of the products
- Conveyors come with height adjustable support frames
- Complete with control cabinet, Weighing Terminal, Process Control Software, connection to printer, PC's and PLC's by serial outputs, Ethernet and Profibus outputs etc.
- ATEX versions also available
- Our Belt Weighing and Checking Systems can be delivered in painted mild steel, partly or complete in stainless steel 304 and/or 316L (food grade)

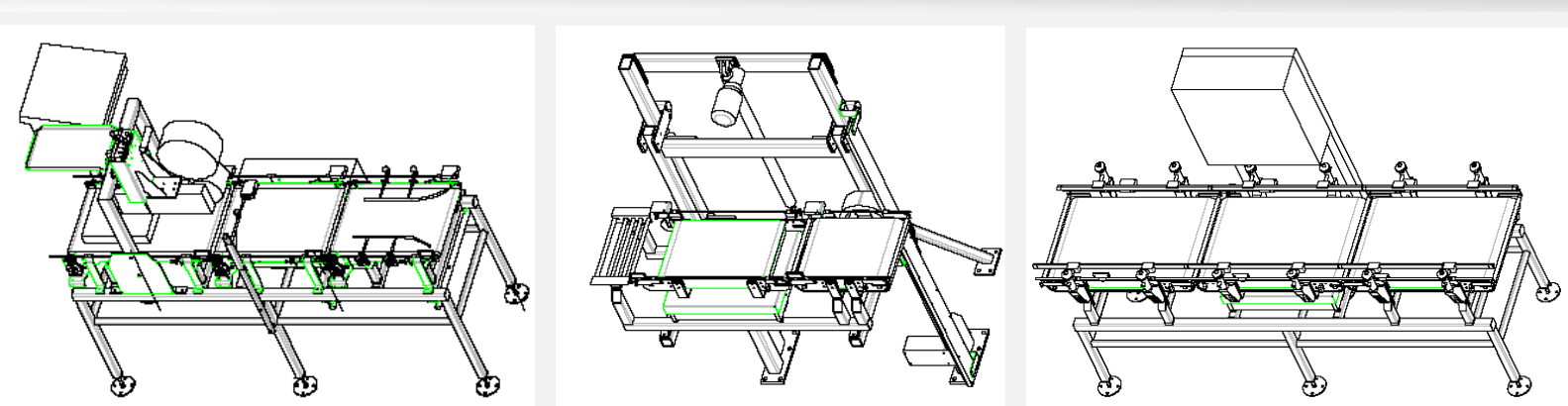

Professional Checkweighers

Checkweighers



Quality guarantee

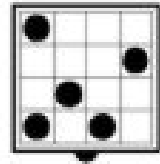

Professional Checkweighers

Servo Berkel Prior B.V.

Jan Evertsenlaan 4 - NL-2224 SV Katwijk
P.O. Box 2032 - NL-2220 BA Katwijk

T. +31 (0) 71 403 01 01
F. +31 (0) 71 403 23 17
E. sales@servoberkelprior.eu
www.servoberkelprior.eu